

MARKETING | RESEARCH ARTICLE

Analysis of the Dynamic Capabilities of Sidoarjo SME in Improving the Performance of Sustainable Innovation

Miftaql Bima Prasetya¹, Laily Muzdalifah², Muhafidhah Novie³, Afifat Sholikhah⁴

^{1,2,3,4}Universitas Nahdlatul Ulama Sidoarjo, Sidoarjo. Indonesia. Email: 31421031.student@unusida.ac.id

ARTICLE HISTORY

Received: April 14, 2025

Revised: May 20, 2025

Accepted: July 01, 2025

DOI

<https://doi.org/10.52970/grmapb.v6i1.1243>

ABSTRACT

This study analyzes the role of four dimensions of dynamic capabilities: Perceptual Ability, Analytical Competence, Unification Expertise, and Harmonization Capacity in encouraging Sustainable Innovation Performance in SMEs in Sidoarjo Regency. A quantitative approach with a sample of 121 SMEs showed that Harmonization Capacity had a positive and substantial influence on sustainable innovation performance. In contrast, Analytical Competence and Coordination Capacity showed a significant positive effect. In contrast, Integration Capabilities did not show a significant influence. These findings underscore the importance of the learning process and strategic coordination in increasing the sustainable innovation capacity of Sidoarjo SMEs, with practical implications for the development of supporting policies and strengthening the managerial capabilities of local SMEs.

Keywords: Dynamic Capabilities, Sustainable Innovation Performance, Sidoarjo SMEs, Business Transformation, Local Economic Sustainability.

JEL Code: L26, O31, M10, Q56, R11.

I. Introduction

The development of SMEs in Sidoarjo has an important role in driving local economic growth, providing jobs, and increasing local income. The industry offers diverse culinary products that attract local consumers and tourists (Putra & Setiadi, 2024). However, with increasing public awareness of sustainability issues, SMEs are increasingly required to develop environmentally friendly and sustainable business practices. Sustainable innovation, both in terms of products and processes, is the key to the competitiveness of SMEs in an increasingly competitive market (Ambarini et al., 2024). According to BPS data, this sector is an important part of Sidoarjo's economic structure, supported by many SMEs and talent, to continue attracting tourists and locals. The main problem is how Sidoarjo SMEs can develop and optimize their dynamic capabilities to achieve sustainable innovation performance amid resource limitations and increasing competitive pressures.

Data (BPS Sidoarjo Regency, 2024). As shown in Figure 1, the distribution of SMEs varies between sub-districts; the distribution of Small and Medium Enterprises (SMEs) shows variations in each sub-district. Sidoarjo District has the highest number of SMEs, reaching 194 units. Taman follows this with 115 and Waru with 113. Districts with fewer SMEs include Tarik (34 SMEs), Jabon (38 SMEs), and Balong Bendo (48 SMEs). Overall, this data reflects the different concentrations of SMEs in Sidoarjo Regency, which are influenced by



population, market access, and infrastructure in each sub-district. Sidoarjo SMEs face several significant challenges that hinder the development of their innovative capabilities. Limited access to capital, cutting-edge technology, and managerial skills are key barriers that limit the capacity of SMEs to implement sustainable innovation and maintain long-term competitiveness (Muawanah & Pujiyanto, 2024). This condition raises concerns about the sustainability of the SME sector in Sidoarjo Regency, which is facing increasingly complex market dynamics.



Figure 1. Number of SME in Sidoarjo Year 2024

Previous literature shows that dynamic capabilities are crucial in driving organizational innovation performance. (Pitelis et al., 2023) Identify that companies with strong sensing capabilities demonstrate excellence in identifying innovation opportunities in the market. However, Pennetta et al. (2024) revealed that SMEs often find it difficult to optimize these capabilities due to limited resources. In the learning dimension, Barbosa & Carvalho (2024) found a positive correlation between acquisitive competence and improved innovation performance, while S. Zhou & May (2024) identified the failure of SMEs to invest in the learning process, which impacts their weak adaptive capacity. The aspect of integrative capability also plays an important role, as shown by the findings (Arroyabe et al., 2024) that integrating external knowledge contributes significantly to the success of innovation. However, Barbosa and Carvalho (2024) identified challenges for SMEs in integrating knowledge effectively. On the coordination dimension, Arroyabe et al. (2024) emphasize the importance of coordinating capacity in optimizing resource allocation for innovation. However, Zahra et al. (2022) found that weak coordination and limited managerial expertise often hinder the effectiveness of the deployment of innovation resources in SMEs. Although Sidoarjo SMEs have great potential, few can develop the dynamic capabilities needed to adapt to market transformation and realize sustainable innovation (Jumaroh & Suryaningrum, 2024). Previous research indicates that while dynamic capabilities—including perception, acquisition, integration, and coordination—are critical to the success and sustainability of SMEs, many SMEs face constraints regarding resources, knowledge, and technology support (Akenroye et al., 2020). The existing study has not comprehensively analyzed the inhibiting factors that cause the limitations of Sidoarjo SMEs in implementing dynamic capabilities effectively.

Based on the research gap, this study aims to analyze "Analysis of the Dynamic Capabilities of Sidoarjo SMEs in Improving the Performance of Sustainable Innovation". The contribution of this research is to provide a new understanding of the role of the four dimensions of dynamic capabilities—Perceptive Ability, Analytical Competence, Unification Expertise, and Harmonization Capacity—in improving the sustainable innovation performance of Sidoarjo SMEs. In addition, this research is also expected to provide practical recommendations for developing the capabilities of Sidoarjo SMEs to increase competitiveness and sustainability amid changing market dynamics. In the next section, this article will present a literature review on sustainable innovation's dynamic capabilities and performance, followed by an explanation of the research methodology that includes research design, sampling methods, and data analysis techniques. Next, the research results and their implications will be presented, and the discussion will close with conclusions and recommendations for future research.

II. Literature Review and Hypothesis Development

2.1. Theoretical Foundations

2.1.1. Dynamic Capacity

Dynamic capacity is the ability of a company to reorganize, integrate, and develop internal and external competencies in response to rapidly changing business environments. This concept, developed by D. J. Teece et al. (1997) and then expanded by Pitelis et al. (2023), has particular significance for SMEs because it provides a framework for understanding how companies with limited resources can remain competitive in a dynamic business environment. In the context of this research, dynamic capacity is seen as an important factor that enables SMEs to develop sustainable innovation to achieve long-term competitive advantage. A comprehensive study conducted by Al Dhaheri et al. (2024) investigates the influence of soft capacity in facilitating SMEs' competitiveness, especially during market turbulence. Their findings revealed that sensory and unifying skills were more influential in maintaining competitiveness than learning and coordination skills (Taghizadeh et al., 2023). In a study conducted by Muhammadin et al. (2020), it was found that dynamic capabilities exerted a positive but insignificant influence on organizational performance in the banking sector, while marketing strategies showed a more dominant contribution.

2.2. Sensing Capabilities

Sensing capabilities, as part of an ever-evolving competency structure, demonstrate the company's talent for differentiating prospects and risks in the commercial landscape through the continuous scanning, search, and exploration of new technologies and market needs. Several studies highlight the importance of sensing capabilities. (Inayah et al., 2024; D. J. Teece et al., 1997) Companies must constantly monitor the external environment to adapt to technological shifts and market needs. These findings align with the view (Bogodistov & Schmidt, 2024) and (Othman, 2016) that prior knowledge and investment in research and development activities are important factors that enable SMEs to recognize and absorb new external information. A key contribution of these studies to current studies is a clear conceptual framework of how sensing capabilities can be developed and measured in the context of SMEs. Based on the synthesis of literature, the key elements of sensing capabilities include identifying business opportunities, assessing the influence of organizational contexts, reviewing product development, and implementing product ideas (Taghizadeh et al., 2023). These elements form the basis for operationalizing the construct in this study.

2.3. Learning Ability

Learning ability is a dynamic capacity dimension essential for SMEs to adapt, innovate, and develop in a changing business environment. Learning capabilities bridge the process of sensing and integration by enabling organizations to process the information gained into actionable knowledge. One of the main components of learning ability is absorptive capacity, which refers to an organization's ability to identify, assimilate, and exploit new knowledge, which was later reinforced by the findings (Barbosa & Carvalho, 2024), indicating that companies with high absorbent capacity have a greater chance of innovating and maintaining a competitive advantage in the long run. Research (Barbosa & Carvalho, 2024) has particular significance for this research because it demonstrates how SMEs can develop absorptive capacity through investment in human resource development, knowledge management practices, and organizational cultures that support continuous learning. In the context of SMEs, where resources are often limited, these findings provide a practical framework for efficiently optimizing organizational learning processes. Moreover, Slang (2024) underscores the importance of organizational learning culture in ensuring the knowledge gained can be applied and shared effectively across the organization. This research contributes to a deeper understanding

of the social and organizational mechanisms that underpin the learning process in SMEs, which often have more flexible and informal structures than large companies. Based on this integration of the literature, the current research adopts a multidimensional view of learning abilities, including the learning process's technical, social, and organizational aspects.

2.4. Integrating Capabilities

Integrating capabilities is an essential skill that helps companies combine resources, knowledge, and practices from internal and external sources to improve performance. According to Pitelis et al. (2023), this ability is critical for coordinating resources and integrating knowledge across different departments and external partners. These capabilities help align strategic objectives with day-to-day operations, allowing for the efficient use of resources for competitive advantage. In the context of SMEs, integration capabilities have unique characteristics that differ from those of large companies. (Novella et al., 2022) demonstrate that SMEs with strong integration capabilities can leverage their relational networks with stakeholders, suppliers, and customers to access resources and knowledge unavailable internally. These findings are highly relevant to this study as they show that SMEs can compensate for their internal resource limitations by developing effective integration capabilities. Based on the literature synthesis, indicators of integration ability include: the ability to provide input, understanding tasks, identifying member skills, coordinating actions, and integrating activities (Taghizadeh et al., 2023). These indicators form the basis for operationalizing the construct in this study.

2.5. Coordination Ability

Coordination skills are a company's ability to unify and align various activities, resources, and knowledge from various internal units and external partners to achieve strategic objectives efficiently. A study by Taghizadeh (2024) underlines the function of capacity harmonization in driving enduring novelty performance across trim to medium-sized enterprises, especially in high-marketed environments, levels of uncertainty, and transformation. (Moussa et al., 2023) show that coordinating efficiently across different business units is essential to drive innovation and improve organizational performance. Based on the synthesis of the literature, this study adopts a framework developed by Taghizadeh et al. (2023) to operationalize the coordination ability construct, which includes the following indicators: alignment of work results, allocation of resources, assignment according to skills, matching skills with work processes, and group coordination. These indicators reflect the technical, social, and organizational dimensions of coordination skills relevant to the SME context.

2.6. Sustainable Innovation Performance

Continuous Novelty Performance demonstrates a company's talent for producing nascent goods, services, or procedures that meet market demand and constructively impact ecological and social goals (Akhtar et al., 2024). Research shows that sustainable innovation involves the integration of technological advances and strategic collaboration (Kastelli et al., 2024). Companies implementing sustainability-based innovations improve their brand reputation and foster trust among stakeholders, including customers, investors, and employees (Y. Zhou et al., 2023). As the basis for operationalizing the continuous innovation performance construct, this study adopts a framework in which Rauf et al. (2024) integrate economic, social, and environmental perspectives to measure innovation performance. The indicators identified include: environmental efficiency, which shows the extent to which innovation can reduce negative impacts on the environment; and sustainable product innovation, which refers to a company's ability to create environmentally friendly or recyclable material-based products that provide added value to customers

(Pavlou et al., 2011; Taghizadeh et al., 2023). This multidimensional approach provides a more comprehensive understanding of how SMEs' dynamic capacity contributes to sustainable innovation performance.

2.7. Framework for Thinking

This section integrates the earlier theoretical constructs to develop a conceptual framework that guides this research. The framework focuses on the relationship between the four dimensions of dynamic capacity (sensing ability, learning ability, integration ability, and coordination ability) and the sustainable innovation performance of SMEs. It is important to note that this framework reflects the linear relationships between independent and dependent variables and considers the complex and dynamic interactions between different dimensions of dynamic capacity in the context of SMEs.

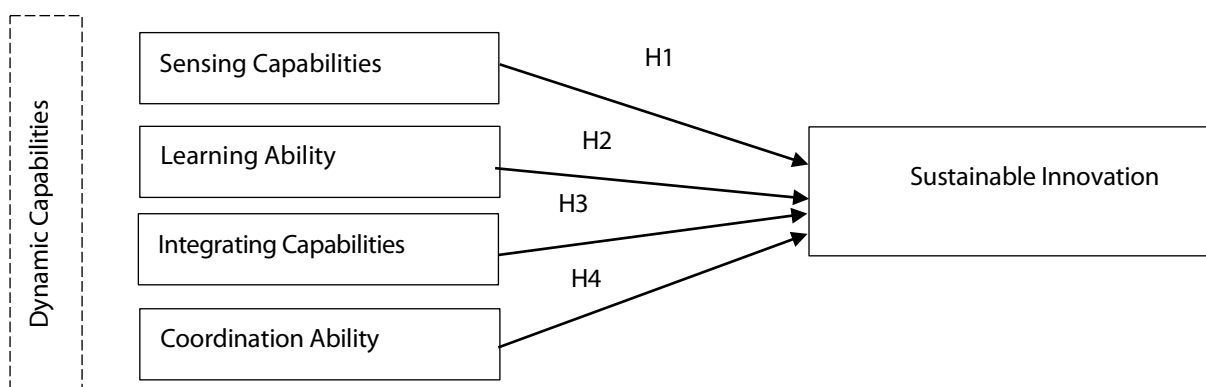

Based on a comprehensive synthesis of the literature, this study proposes four main hypotheses that illustrate the relationship between the dimensions of dynamic capacity and the sustainable innovation performance of SMEs:

H1: Sensing ability positively affects SMEs' sustainable innovation performance.

H2: Learning ability positively affects SMEs' sustainable innovation performance.

H3: Integrating capabilities positively affects the sustainable innovation performance of SMEs.

H4: Coordination ability positively affects SMEs' sustainable innovation performance.

These hypotheses reflect the expected causal relationship between the variables and are the basis for empirical research design. By testing this hypothesis, this research aims to contribute significantly to the theoretical and practical understanding of how SMEs can develop dynamic capacity to achieve sustainable innovation performance in a context characterized by rapidly changing business environments and increasing demands for sustainability.

III. Research Method

This study uses a quantitative approach to analyze SMEs' dynamic ability to achieve sustainable innovation performance in Sidoarjo Regency. The research population consists of 1,314 SMEs operating in Sidoarjo Regency based on data (BPS Sidoarjo Regency, 2024) Sample size is determined using the Slovin formula with the following formula:

$$n = \frac{N}{1 + N \cdot e^2}$$

Information:

n = Required sample size

N = Total population (1,314 SMEs)

e = Margin error (10%)

Calculation of sample size:

$$n = \frac{1.314}{1 + 1.314 \cdot (0,1)^2} = \frac{1.314}{1 + 13,14} = \frac{1.314}{14,14} = 92,93$$

Based on this calculation, the minimum number of samples needed is 93 SMEs. To anticipate the possibility of an incomplete response, this study assigned 104 SMEs as the target of the research sample. Sampling was carried out using a purposive sampling technique with the following criteria: (1) SMEs that have been operating for at least two years, (2) have at least one product or innovation process, and (3) are registered with the Sidoarjo Regency Cooperatives and MSMEs Office.

3.1. Data Collection

Primary data was obtained by distributing a structured questionnaire to the owners or managers of SMEs, which comprised the research sample. The questionnaire was developed based on the operationalization of research variables and has passed the pilot test stage on 30 respondents to ensure the validity and reliability of the instruments. Data was collected in February-March 2025 with in-person visit methods and online surveys to maximize response rates. Secondary data is obtained from official publications such as the Sidoarjo Regency BPS report, Cooperatives and MSMEs Office documents, and relevant scientific publications regarding the dynamic capabilities of SMEs and sustainable innovation. Secondary data sources are selected based on credibility, relevance to the research topic, and novelty of the information (maximum last 5 years).

3.2. Variables and Measurements

This study used a 5-point Likert scale (1 = strongly disagree to 5 = strongly agree) to measure the following variables:

3.2.1. Dynamic Ability (Exogenous Variable)

1. Sensing capability: measured through 5 indicators
2. Seizing capability: measured through 5 indicators
3. Reconfiguring capability: measured through 5 indicators

3.2.2. Sustainable Innovation Performance (Endogenous Variable)

1. Product innovation: measured through 4 indicators
2. Process innovation: measured through 4 indicators
3. Economic sustainability: measured through 3 indicators
4. Environmental sustainability: measured through 3 indicators
5. Social sustainability: measured through 3 indicators

3.2.3. Mediation Variables

1. Organizational learning capabilities: measured through 4 indicators
2. Entrepreneurial orientation: measured through 5 indicators

The development of indicators refers to a comprehensive literature review and previous research, such as (D. Teece et al., 2016), (Zahra & George, 2002), and (Schaltegger et al., 2016), with modifications according to the context of SMEs in Indonesia.

3.3. Theoretical Framework

This research is based on the Dynamic Capabilities Theory (D. J. Teece et al., 1997), which describes an organization's ability to integrate, build, and reconfigure internal and external competencies in the face of changing environments. Dynamic capabilities are seen as a crucial aspect for SMEs to achieve sustainable innovation performance by adapting and transforming their resources. Based on this theoretical framework, this study developed the following hypotheses:

H1: Dynamic capabilities have a positive effect on the sustainable innovation performance of SMEs

H2: Organizational learning capabilities mediate the relationship between dynamic capabilities and continuous innovation performance

H3: Entrepreneurial orientation mediates the relationship between dynamic capabilities and sustainable innovation performance.

3.4. Data Analysis Techniques

This study uses the Structural Equation Modeling method with the Partial Least Squares (SEM-PLS) approach for data analysis with the following considerations:

1. Compatibility with complex research models with latent constructs and mediating relationships
2. Ability to handle moderate-sized samples ($n = 104$)
3. Flexibility in data distribution requirements
4. Ability to analyze measurement and structural models simultaneously

Data analysis using SmartPLS 4.0 software goes through the following stages:

3.4.1. Evaluation of Measurement Models (Outer Model)

1. Convergent validity test (loading factor > 0.7 ; EFA > 0.5)
2. Discriminant validity test (Fornell-Larcker criteria; HTMT < 0.9)
3. Reliability test (Composite Reliability and Cronbach's Alpha > 0.7)

3.4.2. Evaluation of Structural Models (Inner Model)

1. Coefficient of determination (R^2)
2. Predictive relevance (Q^2)
3. Path coefficient and significance (t-statistics > 1.96 or p-value < 0.05)
4. Effect size (f^2)
5. Variance Inflation Factor (VIF < 5) to detect multicollinearity

3.4.3. Mediation Analysis

1. Testing of direct and indirect effects
2. Specific indirect effects
3. Variance Accounted For (VAF) to determine the mediation level

Hypothesis testing used the bootstrapping method of 5,000 resamples to produce more accurate t-statistical values and confidence intervals.

3.5. Validity and Reliability

A series of tests was performed to ensure the reliability of the study's results. For example, the questionnaire was evaluated by three experts in innovation management and SME entrepreneurship to ensure the relevance and accuracy of the measurements. Preliminary tests on 30 respondents were conducted to verify the validity and reliability of the instrument before full-scale deployment. The use of procedural remedies techniques such as respondent confidentiality, variation in response formats, and separation of measurement of predictor variables and criteria. Non-Response Bias Analysis compares the initial and final responses to ensure no systematic differences.

3.6. Research Ethics

This research is carried out by complying with the ethical principles of research, including: Informed consent from all respondents, Guarantee of confidentiality and anonymity of individual data, Use of data for academic purposes only, Respect for intellectual property through proper citation, Openness in reporting research methodologies and findings.

IV. Results and Discussion

4.1. Characteristics of Research Respondents

According to the findings of the study. A questionnaire was sent to 121 SME owners in Sidoarjo; most respondents were women (57.0%), with S1/S2/S3 educational backgrounds (52.9%). The most common business sector is culinary (24.8%), followed by fashion and accessories (16.5%). Most businesses have been established for 3-10 years (38.8%), followed by newly established businesses (<3 years) at 31.4% and those that have been established for more than 10 years at 28.1%. Respondents are dominated by the productive age group, which reflects SME owners with sufficient experience in managing their businesses.

Table 1. Data of Respondent

| Variable | | Frequency | Percentage |
|--|-------------------------------|-----------|------------|
| Gender | Man | 52 | 43.0 |
| | Woman | 69 | 57.0 |
| Education | High School/Vocational School | 57 | 47.1 |
| | S1 / S2 / S3 | 64 | 52.9 |
| The length of time the business has been Run | Newly established (<3 years) | 38 | 31,4 |
| | Intermediate (3-10 years) | 49 | 40,5 |
| | Established (>10 years) | 34 | 28,1 |
| Business Type | Fashion and Accessories | 20 | 16,5 |
| | Culinary | 30 | 24,8 |
| | Beauty | 12 | 9,9 |
| | Craft | 15 | 12,4 |

| Variable | Frequency | Percentage |
|-------------|-----------|------------|
| Textile | 10 | 8,3 |
| Technology | 8 | 6,6 |
| Building | 14 | 11,6 |
| Agriculture | 12 | 9,9 |
| Total | 121 | 100 |

4.2. Results of Instrument Testing

4.2.1. Validity and Reliability Test

The measurement type resilience check assessment omitted 18 metrics from the initial set of 24, resulting in 18 metrics that showed a factor coefficient exceeding 0.7 and were thus considered valid. The convergent validity assessment parameters were ascertained by analyzing the results of the SmartPLS algorithm, focusing on the indicator weight and the Average Extracted Variance After the elimination process, the resulting external load showed that all remaining items had a value greater than 0.7, allowing the interpretation that all these items were suitable for inclusion in the research model (Hair et al., 2020).

Table 2. Item Measurement, Outer Loading, Reliability, and AVE

| Code | Item Measurement | Loading Factor | Cronbach Alpha | Composite Reliability | AVE |
|--------------------------|---|----------------|----------------|-----------------------|-------|
| Sensing Capabilities | | | | | |
| X1.1 | Businesses regularly monitor the environment for new business opportunities | 0,742 | 0,747 | 0,840 | 0,767 |
| X1.3 | Businesses regularly review product development to ensure it meets customer needs. | 0,748 | | | |
| X1.4 | Businesses allocate much time to implement product ideas | 0,790 | | | |
| X1.5 | New products or improving existing products. | 0.700 | | | |
| Learning Ability | | | | | |
| X2.3 | Businesses are adept at turning existing data into new insights. | 0,727 | 0,762 | 0,839 | 0,717 |
| X2.4 | Businesses are adept at leveraging insights to produce innovative goods. | 0,734 | | | |
| X2.5 | Businesses are adept at generating new insights that can help with product development. | 0,812 | | | |
| Integrating Capabilities | | | | | |
| X3.1 | The business is open to providing input to the team. | 0,735 | 0,838 | 0,885 | 0,706 |
| X3.2 | Business actors have a clear understanding of the duties and responsibilities of each member. | 0,733 | | | |
| X3.3 | Businesses know which individuals in the group have specific proficiency and understanding related to team tasks. | 0,796 | | | |
| X3.4 | Businesses can adapt their actions accordingly to deal with changing situations. | 0,837 | | | |
| X3.5 | Business members connect their activities well so that | 0,787 | | | |

| Code | Item Measurement | Loading Factor | Cronbach Alpha | Composite Reliability | AVE |
|---|--|----------------|----------------|-----------------------|-------|
| | Resulting in successful cooperation. | | | | |
| Coordination Ability | | | | | |
| X4.1 | Businesses ensure that each member's work matches the work of other members. | 0,768 | 0,701 | 0,848 | 0,759 |
| X4.2 | Businesses ensure resources (information, time, or reports) are distributed correctly. | 0,757 | | | |
| X4.4 | Businesses ensure that each member's skills match the work process. | 0,731 | | | |
| X4.5 | Business actors are well coordinated overall. | 0,749 | | | |
| Sustainable Innovation Performance | | | | | |
| Y3 | Entrepreneurs can bring new products to market quickly. | 0,822 | 0,776 | 0,846 | 0,732 |
| Y4 | Businesses are good at identifying and taking advantage of new market opportunities. | 0,727 | | | |
| Y5 | Products produced by businesses are delivered on time and meet quality standards. | 0,817 | | | |

Based on the results in Table 2, all indicators show loading factor values exceeding the threshold of 0.7, indicating that the validity criteria are met for all indicators used. The X3.4 indicator shows the highest value (0.837), while the X2.3 indicator has the lowest value (0.727). Judging from the reliability aspect, all constructs in this study have a Cronbach's Alpha value above 0.7, confirming the research instrument's reliability. In addition, the Composite Reliability value, exceeding 0.7 for all constructs, further strengthens the fact that these variables meet the reliability requirements. An Average Variance Extracted (AVE) value that exceeds 0.5 on all variables indicates that the data is valid and meets the convergent validity criteria outlined in the PLS-SEM analysis.

4.2.2. Variance Inflation Factor (VIF)

Table 3. VIF

| | VIF |
|-----------|-------|
| SC -> SIP | 1.408 |
| LC -> SIP | 1.634 |
| IC -> SIP | 2.634 |
| CC -> SIP | 2.678 |

The evaluation results in Table 3 show that the internal VIF value for all lines is below 5. This indicates that the level of collinearity between indicators is minimal. These findings strengthen the validity of the results of the coefficient estimation in the PLS-SEM model, which shows that the estimate is robust and unbiased (Hair et al., 2020).

4.2.3. R Square

The coefficient of determination (R^2) is one of the parameters to evaluate the model's predictive power. An R^2 value above 0.25 is classified as weak, above 0.50 is classified as moderate, and above 0.75 is classified as substantial. The following are the results of the R-Square analysis obtained:

Table 4. R Square

| | R Square | R Square Adjusted |
|-----|-----------------|--------------------------|
| SIP | 0.964 | 0.963 |

Based on Table 4, the value of the determination coefficient for the Sustainable Innovation Performance (SIP) construct is 0.963 or 96.3%. These results show that the variation in Sustainable Innovation Performance can be explained by 96.3% by the four independent variables studied (Sensing Ability, Learning Ability, Integration Ability, and Coordination Ability). Thus, this research model has very high predictive power and belongs to the substantial classification.

4.3. Estimated Path Coefficients

The Partial Smallest Square Structural Equation Modeling Technique results in a normalized directional influence (β) covering a range of -1 to +1. Directional influence close to +1 indicates a substantial affirmative association, while a value close to -1 indicates a strong inverse association in the interval of -1 to +1. At the same time, the hypothesis between variables is assessed using t-scores or probability metrics. If the derived t-score exceeds 1.96 (critical t-value) or the probability of the analysis result is below 0.05, an important influence among the constructs is seen.

Table 5. Hypothesis Testing

| | Original Example | P-Value (STDEV) | Statistics T (O/STERR) | P-Value | Result | Decision |
|-----------|-------------------------|------------------------|---------------------------------|----------------|----------------------|-----------------|
| SC -> SIP | -0,065 | 0,025 | 2,617 | 0,009 | Positive Significant | H1 Accepted |
| LC -> SIP | 0,967 | 0,021 | 47,030 | 0,000 | Positive Significant | H2 Accepted |
| IC -> SIP | -0,019 | 0,033 | 0,578 | 0,558 | UnSignificant | H3 Rejected |
| CC -> SIP | 0,088 | 0,039 | 2,268 | 0,023 | Positive Significant | H4 Accepted |

Based on the results of hypothesis testing presented in Table 5, several important findings were obtained that became the main contribution to this study:

1. The value of the coefficient of the sensory ability variable path of Sensing Ability (SC) on Sustainable Innovation Performance (SIP) was -0.065 with a t-statistical value of 2.617 (>1.96) and a p-value of 0.009 (<0.05). These results show that SC has a significant influence, but with a negative relationship direction. These findings present a new perspective different from previous studies, indicating the complexity of the relationship between Sensing Capabilities and Sustainable Innovation Performance in the context of SMEs in Sidoarjo.
2. The value of the coefficient of the Learning Ability variable path (LC) on Sustainable Innovation Performance (SIP) was 0.967 with a t-statistical value of 47.030 (>1.96) and a p-value of 0.000 (<0.05). These results confirm that LC has a positive and significant influence on SIP, with the highest coefficient among other variables. These findings reinforce the argument that the ability to absorb and apply new knowledge is a key factor in driving sustainable innovation in SMEs.
3. The value of the coefficient of the Ability to Integrate variable path (IC) on Sustainable Innovation Performance (SIP) was -0.019 with a t-statistical value of 0.578 (<1.96) and a p-value of 0.558 (>0.05). These results suggest that IC has a negative but insignificant influence on SIP. These findings open up a new space for discussion about the relevance and context of the application of Integrating Capabilities in the SME ecosystem in Indonesia.
4. The Effect of Coordination Ability on Sustainable Innovation Performance. The value of the coefficient of the Coordination Ability (CC) variable path to Sustainable Innovation Performance (SIP) was 0.088 with a t-statistical value of 2.268 (>1.96) and a p-value of 0.023 (<0.05). These results confirm that CC positively and significantly influences SIP, albeit with a relatively small coefficient compared to Learning Ability.

4.4. Discussion

4.4.1. The Effect of Sensing Capabilities on Sustainable Innovation Performance

The study's findings show that Sensing Ability (SC) significantly influences Sustainable Innovation Performance (SIP) in SMEs in Sidoarjo, but with a negative relationship direction. These results present a new perspective that differs from conventional assumptions and previous studies that generally indicate a positive relationship between the two variables. This phenomenon can be interpreted through several theoretical and contextual perspectives. First, in the context of SMEs in Sidoarjo, too many market sensing activities without concrete actions can result in information overload and strategic confusion. SMEs with high sensing capabilities but not balanced with the capacity to process and utilize the information effectively tend to experience analysis paralysis, where too many alternatives and information hinder the decision-making process and implementation of innovation. Second, the context of competition and market dynamics in Sidoarjo may require a more focused and specialized approach. SMEs that are overly responsive to market changes risk losing their identity and continued competitive advantage. This is in line with the Resource-Based View (RBV) theory, which emphasizes the importance of building capabilities that are unique and difficult for competitors to replicate (Barney, 1991). These findings enrich academic discussions by presenting new nuances in understanding the relationship between dynamic capabilities and sustainable innovation performance. In contrast to research (Rinawiyanti et al., 2017) stating that innovation competence has a significant positive effect on SME performance, this study reveals the complexity and possibility of a non-linear relationship between Sensing Ability and Sustainable Innovation Performance that needs further exploration. These results also indicate the importance of a more integrated approach in developing the dynamic capabilities of SMEs. It is not enough to rely only on high Sensing Skills; SMEs in Sidoarjo need to strengthen other skills, especially Learning Skills and Coordination Skills, to optimize the performance of their sustainable innovations.

4.4.2. The Influence of Learning Ability on Sustainable Innovation Performance

The study results show that Learning Ability positively and significantly influences the Performance of Sustainable Innovation in SMEs in Sidoarjo. These findings are an important empirical contribution to the dynamic capability literature, especially in the context of SMEs in Indonesia. Learning ability proved to be a key determinant factor in driving sustainable innovation, with the highest path coefficient (0.967) compared to other dynamic abilities. This indicates that in the context of SMEs in Sidoarjo, the capacity to absorb, integrate, and apply new knowledge is the key to maintaining long-term innovation performance. This finding can be explained through the Knowledge-Based View (KBV) perspective, which emphasizes that knowledge is an organization's most valuable strategic resource (Grant, 1996). SMEs that can develop effective organizational learning mechanisms will have an advantage in identifying market opportunities, developing innovative solutions, and adapting to changing business environments. The results of this study expand on the findings (Pujianto et al., 2023), which state that organizations with high learning capacity can more easily update and improve knowledge and skills. The new contribution of this research is to confirm that in the context of SMEs in Sidoarjo, Learning Ability has a much more dominant role compared to other dynamic abilities in encouraging sustainable innovation. In practical terms, these findings imply the importance of investing in Learning Ability development for SMEs that want to improve sustainable innovation performance. This can be realized through various initiatives such as continuous training, collaboration with educational and research institutions, and developing a learning culture that encourages experimentation and knowledge sharing within the organization.

4.4.3. The Effect of Capability Integration on Sustainable Innovation Performance

The study results show that the Ability to integrate has a negative but insignificant influence on the Performance of Sustainable Innovation in SMEs in Sidoarjo. These findings present a different perspective from the theoretical assumptions that generally indicate a positive relationship between the two variables. Although these results contradict some previous studies, they are consistent with research (Firmansyah & Priyono, 2022), which explains that SMEs cannot rely solely on resource integration but must develop other capabilities more relevant to the context and challenges. These findings open up a new discussion on the contextuality of applying the Ability to Integrate concept in Indonesia's SME ecosystem. The insignificant influence of the Integrating Ability can be interpreted through several perspectives. First, the organizational structure of SMEs, which tends to be more straightforward and flexible, may make integrating resources and knowledge more natural and less formal than with large companies. This is in line with the findings (Sarwar et al., 2024), which states that the impact of Integration Ability on Sustainable Innovation Performance tends to be stronger in large companies compared to SMEs. Second, the socio-cultural context in Indonesia, particularly in East Java, which emphasizes harmony and cooperation, may have created an environment where the integration of resources and knowledge occurs as part of social norms, rather than as structured organizational capabilities. In this context, the formal development of Integrating Capabilities may not provide significant added value to the innovation performance of SMEs. Although not significant, the direction of the negative relationship between Ability to Integrate and Sustainable Innovation Performance indicates a potential trade-off or complexity that needs to be explored further. One possible explanation is the occurrence of core rigidities where formal efforts to integrate resources and knowledge create bureaucracy and hinder the flexibility and creativity needed in the innovation process (Leonard-Barton, 1992). These findings imply the need for a more contextual and adaptive approach in developing Integration Skills in SMEs in Indonesia. Instead of adopting formal practices that may be more appropriate for large companies, SMEs need to develop integration mechanisms more aligned with their specific characteristics and needs.

These results align with the findings (Wijayanti et al., 2012), which suggest that the contribution of structural capital to innovation is not uniform across industrial sectors and tends to be influenced by the scale and complexity of the organization. In the context of SMEs, limitations in structural capital management and cross-unit knowledge integration can undermine the positive impact of integration capabilities on innovation performance, as reflected in the results of this study.

4.4.4. The Influence of Coordination Ability on Sustainable Innovation Performance

The study results show that Capacity Harmonization is important in improving Sustainable Innovation Performance at SMEs in Sidoarjo. When SMEs can effectively coordinate various activities and resources, they can create more sustainable innovation. For example, ensuring that production, marketing, and product development teams work synergistically will facilitate the flow of information and accelerate decision-making in the innovation process. Good coordination is built through factors such as smooth communication between departments, efficient flow of information, and proper resource management. Effective coordination also allows SMEs to manage resources more efficiently, such as data, technology, and markets, which supports better innovation performance. These findings expand the study's results (Taghizadeh et al., 2023), which show that coordination ability significantly impacts the long-term innovation performance of SMEs, especially amid a dynamic environment. A new contribution from this research is to confirm that in the SME ecosystem in Sidoarjo, Coordination Ability has an important role as an enabler that facilitates the transformation of ideas into sustainable innovations. In practical terms, these findings imply the importance of investing in developing Coordination Capabilities for SMEs looking to improve sustainable innovation performance. This can be realized through various initiatives such as developing integrated information systems, improving cross-functional communication, and implementing collaborative and transparent decision-making mechanisms.

V. Conclusion

Based on the data analysis and discussion results, this study produced several important conclusions that contribute to understanding the relationship between dynamic capabilities and sustainable innovation performance in SMEs in Sidoarjo. Sensing Capability significantly influences the Performance of Sustainable Innovation in SMEs in Sidoarjo, but with a negative relationship direction. These findings present a new perspective that differs from conventional assumptions and demonstrate the complexity in the relationship between the ability to recognize opportunities and changes in the business environment and sustainable innovation performance. SMEs must be careful so that market sensing activities do not lead to analysis paralysis, hindering innovation.

Learning Capability has been proven to positively and significantly influence Sustainable Innovation Performance in SMEs in Sidoarjo, with the highest path coefficient among other dynamic capabilities. These findings confirm that in the context of SMEs in Sidoarjo, the capacity to absorb, integrate, and apply new knowledge is a major determinant factor in driving sustainable innovation. Integrating Capability has a negative but insignificant influence on Sustainable Innovation Performance in SMEs in Sidoarjo. These findings indicate that in the context of SMEs in Indonesia, the development of formal capacities to integrate resources and knowledge may not provide significant added value.

References

- Akenroye, T. O., Owens, J. D., Elbaz, J., & Durowoju, O. A. (2020). Dynamic capabilities for SME participation in public procurement. *Business Process Management Journal*, 26(4), 857–888. <https://doi.org/10.1108/BPMJ-10-2019-0447>
- Akhtar, S., Li, C., Sohu, J. M., Rasool, Y., Hassan, M. I. U., & Bilal, M. (2024). Unlocking green innovation and environmental performance: the mediated moderation of green absorptive capacity and green innovation climate. *Environmental Science and Pollution Research International*, 31(3), 4547–4562. <https://doi.org/10.1007/s11356-023-31403-w>
- Al Dhaheri, M. H., Ahmad, S. Z., & Papastathopoulos, A. (2024). Do environmental turbulence, dynamic capabilities, and artificial intelligence force SMEs to be innovative? *Journal of Innovation and Knowledge*, 9(3), 100528. <https://doi.org/10.1016/j.jik.2024.100528>
- Ambarini, L., Trisnawati, N., & Marhalinda. (2024). Product Innovation in Culinary Business MSMEs at Pejuang Morning Market, Bekasi. *Journal of IKRAITH-ABDIMAS*, 8(1), 258–264. <https://doi.org/https://doi.org/10.37817/ikra-ithabdimas.v8i1>
- Argote, L. (2024). Knowledge Transfer Within Organizations: Mechanisms, Motivation, and Consideration. *Annual Review of Psychology*, 75, 405–431. <https://doi.org/10.1146/annurev-psych-022123-105424>
- Arroyabe, M. F., Arranz, C. F. A., Fernandez De Arroyabe, I., & Fernandez de Arroyabe, J. C. (2024). Analyzing AI adoption in European SMEs: A study of digital capabilities, innovation, and external environment. *Technology in Society*, 79(October), 102733. <https://doi.org/10.1016/j.techsoc.2024.102733>
- Barbosa, M. T. J., & Carvalho, M. M. (2024). Absorptive capacity activation triggers: Insights from learning in project epochs of a project-based organization. *International Journal of Project Management*, 42(6), 102637. <https://doi.org/10.1016/j.ijproman.2024.102637>
- Bogodistov, Y., & Schmidt, S. (2024). Affective states and a firm's performance: the mediating role of dynamic managerial capabilities. *Baltic Journal of Management*, 19(6), 111–132. <https://doi.org/10.1108/BJM-09-2023-0352>
- BPS Sidoarjo Regency. (2024). Central Statistics Agency of Sidoarjo Regency, BPS-Statistics of Sidoarjo Regency. Sec. 41.
- Firmansyah, Z. N., & Priyono, A. (2022). The Effect of Supply Chain Integration on Product Innovation Capabilities in MSMEs in Indonesia. *Management Select: Journal of Business & Management Students*, 01(05), 109–120.
- Hair, J. F., Sarstedt, M., Pieper, T. M., & Ringle, C. M. (2020). The Use of Partial Least Squares Structural Equation Modeling in Strategic Management Research: A Review of Past Practices and Recommendations for Future Applications. *Long Range Planning*, 45(5–6), 320–340. <https://doi.org/https://doi.org/10.1016/j.lrp.2012.09.008>

- Inayah, N., Emilisa, N., & Mayrisya, Z. N. F. (2024). The Influence of Digital Leadership and Innovative Culture on Innovation Performance Mediated by Digital Innovation in PT Employees. Bank Central Asia Tbk in Central Jakarta. *Journal of Social Science*, 5(4), 1013–1025. <https://doi.org/10.46799/jss.v5i4.868>
- Jumaroh, D. A., & Suryaningrum, D. H. (2024). Digital Capabilities, Environment, And Business Strategy For MSMEs' Performance In Sidoarjo District. *Journal of Economics, Business and Accounting (COSTING)*, 7(4), 10682–10694. <https://doi.org/10.31539/costing.v7i4.10937>
- Kastelli, I., Dimas, P., Stamopoulos, D., & Tsakanikas, A. (2024). Linking Digital Capacity to Innovation Performance: The Mediating Role of Absorptive Capacity. *Journal of the Knowledge Economy*. <https://doi.org/10.1007/s13132-022-01092-w>
- Muawanah, C. C., & Pujiyanto, W. E. (2024). Innovation Capability on Organizational Performance: Dynamic Marketing Capability as a Mediation Variable. *Dialectics: Journal of Economics and Social Sciences*, 9(1), 88–101. <https://doi.org/10.36636/dialektika.v9i1.3888>
- Muhammadin, A., Ramli, R., Ridjal, S., Kanto, M., Alam, S., & Idris, H. (2020). Effects of dynamic capability and marketing strategy on the organizational performance of the banking sector in Makassar, Indonesia. *Espacio Magazine*, 41(24), 26–41. <https://www.revistaespacios.com>
- Novella, P., Sorel, M., Usón, A., Adams, C., Almazán, H., Álvarez, V., Aparicio, B., Aranburu, A. I., Arazi, L., Arnquist, I. J., Ayet, S., Azevedo, C. D. R., Bailey, K., Ballester, F., Benlloch-Rodríguez, J. M., Borges, F. I. G. M., Bounasser, S., Byrnes, N., Cárcel, S., ... Yahlali, N. (2022). In NEXT, the Xe 136 two-neutrino double- β -decay half-life is measured via direct background subtraction. *Physical Review C*, 105(5). <https://doi.org/10.1103/PhysRevC.105.055501>
- Othman, N. (2016). Exploring the Innovative Personality Characteristics among Teachers. *International Education Studies*, 9(4), 1. <https://doi.org/10.5539/ies.v9n4p1>
- Pavlou, A., P., Sawy, E., & A., O. (2011). Understanding the Elusive Black Box of Dynamic Capabilities. *Decision Sciences*, 42(1), 239–273. <https://doi.org/https://doi.org/10.1111/j.1540-5915.2010.00287.x>
- Pennetta, S., Anglani, F., Reaiche, C., & Boyle, S. (2024). Mapping the Field of Entrepreneurial Versus Managerial Abilities: A New Trend of Dynamic Capabilities- A Bibliometric Analysis. *SAGE Open*, 14(1). <https://doi.org/10.1177/21582440241234718>
- Pitelis, C. N., Teece, D. J., & Yang, H. (2023). Dynamic Capabilities and MNE Global Strategy: A Systematic Literature Review-Based Novel Conceptual Framework. *Journal of Management Studies*, Nov. <https://doi.org/10.1111/joms.13021>
- Pujiyanto, W. E., Musyaffaah, L., & Supriyadi. (2023). Organizational Justice to Employee Innovative Work Behavior: Mediation Effect of Learning Capacity and Moderation Effect of Blue Ocean Leadership. *Greenomics*, 5(1), 77–93. <https://doi.org/10.55732/unu.gnk.2022.05.1.8>
- Putra, I. P., & Setiadi, T. (2024). Promotional Mix Of Gajah Mada Sidoarjo Culinary Center. *The Commercium*, 8(1), 161–171.
- Rauf, F., Wanqiu, W., Naveed, K., & Zhang, Y. (2024). Green R&D investment, ESG reporting, and corporate green innovation performance. *PLoS ONE*, 19(3 March), 1–22. <https://doi.org/10.1371/journal.pone.0299707>
- Rinawiyanti, E. D., Lianto, B., & Soeharsono, F. (2017). Study the Relationship of Innovation Capabilities and Innovation Performance of Footwear SMEs in Mojokerto. *Ajie*, 4(1), 9–20. <https://doi.org/10.20885/ajie.vol4.iss1.art2>
- Sarwar, Z., Gao, J., & Khan, A. (2024). Nexus of digital platforms, innovation capability, and strategic alignment to enhance innovation performance in the Asia Pacific region: a dynamic capability perspective. *Asia Pacific Journal of Management*, 41(2), 867–901. <https://doi.org/10.1007/s10490-023-09879-4>
- Schaltegger, S., Lüdeke-Freund, F., & Hansen, E. G. (2016). Business cases for sustainability: The role of business model innovation for corporate sustainability. *International Journal of Innovation and Sustainable Development*, 6(2), 95–119. <https://doi.org/10.1504/IJISD.2012.046944>
- Taghizadeh, S. K., Rahman, S. A., Nikbin, D., Radomska, M., & Maleki Far, S. (2023). Dynamic capabilities of the SMEs for sustainable innovation performance: role of environmental turbulence. *Journal of Organizational Effectiveness*, 11(4), 768–787. <https://doi.org/10.1108/JOEPP-04-2023-0166>
- Taghizadeh. (2024). National Counterintelligence Strategy - 2024.
- Teece, D. J., Pisano, G., & Shuen, A. (1997). Dynamic Capabilities and Strategic Management. *Strategic Management Journal*, 18(7), 509–533. <https://doi.org/https://doi.org/10.4337/9781035334995.00014>
- Teece, D., Peteraf, M., & Leih, S. (2016). Dynamic capabilities and organizational agility: Risk, uncertainty, and strategy in the innovation economy. *California Management Review*, 58(4), 13–35. <https://doi.org/10.1525/cmr.2016.58.4.13>
- Wijayanti, R., Berliana, N. G., Nadhiroh, I. M., Aminullah, E., Kusnandar, Fizzanty, T., Handayani, T., Rahmaida, R., Laili, N., Kusbiantono, & Handoko, L. T. (2012). The correlation between structural capital and innovation

- in the Indonesian manufacturing industry. ICIMTR 2012 - 2012 International Conference on Innovation, Management and Technology Research, July, 322–325. <https://doi.org/10.1109/ICIMTR.2012.6236411>
- Zahra, S. A., & George, G. (2002). Absorptive capacity: A review, reconceptualization, and extension. *Academy of Management Review*, 27(2), 185–203. <https://doi.org/10.5465/AMR.2002.6587995>
- Zahra, S. A., Petricevic, O., & Luo, Y. (2022). Toward an action-based view of dynamic capabilities for international business. *Journal of International Business Studies*, 53(4), 583–600. <https://doi.org/10.1057/s41267-021-00487-2>
- Zhou, S., & May, W. (2024). Interrelationship Between Entrepreneurial Alertness and Intention Among University Students: A Moderated Mediation Model. *ECNU Review of Education*, 1–27. <https://doi.org/10.1177/20965311241256355>
- Zhou, Y., Yang, C., Liu, Z., & Gong, L. (2023). Digital technology adoption and innovation performance: a moderated mediation model. *Technology Analysis and Strategic Management*, May, 1–16. <https://doi.org/10.1080/09537325.2023.2209203>